

Panasonic®

Digital Proprietary Telephone

User Guide

Model No. KX-T7667

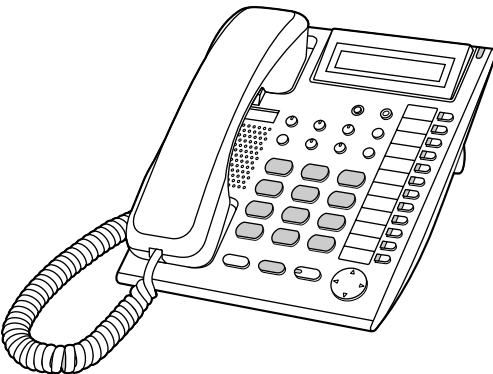

Please read this guide before using and save for future reference.











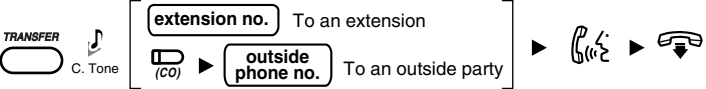



















Document Version: 2006-02

Features List

- Outside (CO) Line button
 Off-hook
 On-hook
 Feature number
 Talk
 Incoming Call Distribution Group button
 Direct Station Selection button
 Confirmation Tone
 Ringback Tone
C. Tone R.B. Tone





















Feature	Operation
Making Calls	
Calling	<p>To an extension</p> ► ►
Redial	► ►
Quick Dialing	► ►
One-touch Dialing	<p>To store</p> ► ► ► ► ►
	<p>To dial</p> ► assigned as a One-touch Dialing button ►
Operator Call	► ►
Personal Speed Dialing	<p>To store</p> ► ► ► ► ► ► ►
	<p>To dial</p> ► ► ► ►
System Speed Dialing	<p>To dial</p> ► ► ►
Doorphone Call	► ► ► ► ►
Automatic Callback Busy	<p>To set</p> <p><i>While hearing a busy tone</i></p>
	<p>To answer from an idle extension</p> <p><i>While hearing a callback ring</i></p>
	<p>To cancel</p> ► ► ►
	<p>To answer from an idle outside line</p> <p><i>While hearing a callback ring</i></p> ► ►
During a Conversation	
Call Hold	<p>To hold</p>
	<p>To retrieve a call at the holding extension</p> ► / / ►
	<p>To retrieve an outside call from another extension</p> ► ►

Features List



























Feature	Operation
During a Conversation	
Call Transfer	 <p>TRANSFER  C. Tone</p> <p>[extension no. To an extension]</p> <p>[(CO) outside phone no. To an outside party]</p> <p> </p>
Useful Features	
Off-hook Monitor	<p>To set/cancel <i>During a conversation using the handset</i></p> <p></p>
Call Park	<p>To set</p> <p>TRANSFER  C. Tone</p> <p>[* 5 2]  [parking zone no. (2 digits) Specified]  C. Tone</p> <p>[*] Auto</p>
	<p>To retrieve</p> <p>  [* 5 2]  [stored parking zone no. (2 digits)] C. Tone </p>
Multiple Party Conversation	<p>To add other parties during a conversation</p> <p>CONF  C. Tone</p> <p>[desired phone no.]   CONF  C. Tone </p> <p>Talk to the new party. Talk with multiple parties.</p>
	<p>To leave a conference</p> <p>CONF  C. Tone </p>
Call Pickup	<p>  [(DSS) * 4 1]  [extension no. Directed]  C. Tone</p> <p>[* 4 0]  [group no. (2 digits) Group]</p>
Sending a Call Waiting Tone	<p><i>While hearing a busy tone</i></p> <p>[1]  Wait for an answer. </p>
Answering a Call Waiting	<p>To hold the current call then talk to the new party</p> <p>HOLD   (CO) / INTERCOM  * </p>

* Disregard this step if both parties are extensions.

Features List

Feature	Operation
Useful Features	
Paging	<p>To page</p>  ▶ * 3 3 ▶ paging group no. (2 digits) C. Tone  ▶ Wait for an answer. C. Tone 
	<p>To answer</p>  ▶ * 4 3 C. Tone 
	<p>To allow/deny a paged announcement</p>  ▶ * 7 2 1 1 Deny * 7 2 1 0 Allow C. Tone 
Message Waiting	<p>Caller</p> <p>To leave a message waiting indication <i>When the called extension is busy or does not answer</i></p>  C. Tone 
	<p>Called extension</p>  ▶  ▶ 
Log-in/Log-out	 ▶ * 7 3 6 1 For Log-in * 7 3 6 0 For Log-out ▶ ICD Group extension no. Specified * All C. Tone 
Before Leaving Your Desk	
Setting Absent Message	<p>To set</p>  ▶ * 7 5 0 ▶ message no. (1-9) ▶ parameter (if required) ▶ # ▶ 
	<p>To cancel</p>  ▶ * 7 5 0 0 ▶ 
Call Forwarding	 ▶ * 7 1 ▶ 0 Both Calls 1 Outside Calls 2 Intercom Calls ▶
	<div style="border: 1px dashed black; padding: 10px;">  ▶ 2 All calls 3 Busy 4 No answer 5 Busy/ No answer 0 Cancel ▶ extension no. OR CO line access no. ▶ outside phone no. ▶ # C. Tone </div>

Features List

Feature	Operation										
Before Leaving Your Desk											
Extension Dial Lock	To lock  ▶ <input type="text" value="*"/> <input type="text" value="7"/> <input type="text" value="7"/> <input type="text" value="1"/>  										
	To unlock  ▶ <input type="text" value="*"/> <input type="text" value="7"/> <input type="text" value="7"/> <input type="text" value="0"/> ▶ <input type="text" value="extension PIN* (max. 10 digits)"/>   <small>*PIN: Personal Identification Number</small>										
Setting the Telephone According to Your Needs											
Do Not Disturb	 ▶ <input type="text" value="*"/> <input type="text" value="7"/> <input type="text" value="1"/> ▶ <table border="1" style="display: inline-table; vertical-align: middle;"> <tr><td><input type="text" value="0"/></td><td>Both Calls</td></tr> <tr><td><input type="text" value="1"/></td><td>Outside Calls</td></tr> <tr><td><input type="text" value="2"/></td><td>Intercom Calls</td></tr> </table> ▶ <table border="1" style="display: inline-table; vertical-align: middle;"> <tr><td><input type="text" value="1"/></td><td>Set</td></tr> <tr><td><input type="text" value="0"/></td><td>Cancel</td></tr> </table>  	<input type="text" value="0"/>	Both Calls	<input type="text" value="1"/>	Outside Calls	<input type="text" value="2"/>	Intercom Calls	<input type="text" value="1"/>	Set	<input type="text" value="0"/>	Cancel
<input type="text" value="0"/>	Both Calls										
<input type="text" value="1"/>	Outside Calls										
<input type="text" value="2"/>	Intercom Calls										
<input type="text" value="1"/>	Set										
<input type="text" value="0"/>	Cancel										
Extension Feature Clear	 ▶ <input type="text" value="*"/> <input type="text" value="7"/> <input type="text" value="9"/> <input type="text" value="0"/>  										
Timed Reminder	To set  ▶ <input type="text" value="*"/> <input type="text" value="7"/> <input type="text" value="6"/> <input type="text" value="0"/> <input type="text" value="1"/> ▶ <input type="text" value="hour/minute (4 digits)"/> ▶ <table border="1" style="display: inline-table; vertical-align: middle;"> <tr><td><input type="text" value="0"/></td><td>AM</td></tr> <tr><td colspan="2" style="text-align: center;">OR</td></tr> <tr><td><input type="text" value="1"/></td><td>PM</td></tr> </table> ▶ ▶ <table border="1" style="display: inline-table; vertical-align: middle;"> <tr><td><input type="text" value="0"/></td><td>once</td></tr> <tr><td><input type="text" value="1"/></td><td>daily</td></tr> </table>  	<input type="text" value="0"/>	AM	OR		<input type="text" value="1"/>	PM	<input type="text" value="0"/>	once	<input type="text" value="1"/>	daily
	<input type="text" value="0"/>	AM									
OR											
<input type="text" value="1"/>	PM										
<input type="text" value="0"/>	once										
<input type="text" value="1"/>	daily										
To cancel  ▶ <input type="text" value="*"/> <input type="text" value="7"/> <input type="text" value="6"/> <input type="text" value="0"/> <input type="text" value="0"/>   To stop or answer the ring back  / 											
Receiving Call Waiting	To set/cancel for intercom calls  ▶ <input type="text" value="*"/> <input type="text" value="7"/> <input type="text" value="3"/> <input type="text" value="1"/> ▶ <table border="1" style="display: inline-table; vertical-align: middle;"> <tr><td><input type="text" value="0"/></td><td>No Call</td></tr> <tr><td><input type="text" value="1"/></td><td>Tone</td></tr> <tr><td><input type="text" value="3"/></td><td>Whisper OHCA</td></tr> </table>  	<input type="text" value="0"/>	No Call	<input type="text" value="1"/>	Tone	<input type="text" value="3"/>	Whisper OHCA				
	<input type="text" value="0"/>	No Call									
<input type="text" value="1"/>	Tone										
<input type="text" value="3"/>	Whisper OHCA										
To set/cancel for outside calls  ▶ <input type="text" value="*"/> <input type="text" value="7"/> <input type="text" value="3"/> <input type="text" value="2"/> ▶ <table border="1" style="display: inline-table; vertical-align: middle;"> <tr><td><input type="text" value="0"/></td><td>No tone</td></tr> <tr><td><input type="text" value="1"/></td><td>Tone</td></tr> </table>  	<input type="text" value="0"/>	No tone	<input type="text" value="1"/>	Tone							
<input type="text" value="0"/>	No tone										
<input type="text" value="1"/>	Tone										



- For more details, refer to the Business Telephone System User Manual or consult your dealer.
- You can change the flexible CO buttons to the feature buttons.
- “Location of Controls” is shown on pages 6-7.

Location of Controls

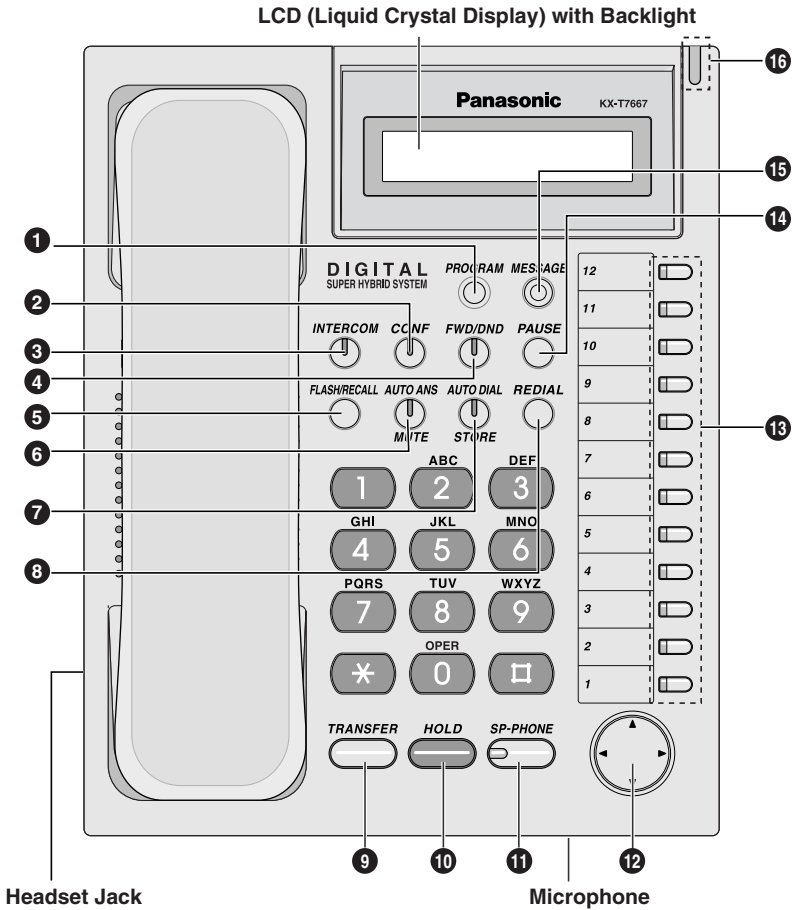

- 1 PROGRAM:** Used to enter and exit the personal programming mode.
- 2 CONF (Conference):** Used to establish a multiple party conversation.
- 3 INTERCOM:** Used to make or receive intercom calls.
- 4 FWD/DND (Call Forwarding/Do Not Disturb):** Used to perform Call Forwarding or Do Not Disturb.
- 5 FLASH/RECALL:** Used to disconnect the current call and make another call without hanging up.
- 6 AUTO ANS (Auto Answer)/MUTE:** Used to receive an incoming call in hands-free mode or mute the microphone/handset during a conversation.
- 7 AUTO DIAL/STORE:** Used for System/Personal Speed Dialing or storing program changes.
- 8 REDIAL:** Used to redial the last dialed number.
- 9 TRANSFER:** Used to transfer a call to another party.
- 10 HOLD:** Used to place a call on hold.

Location of Controls

- 11 SP-PHONE (Speakerphone):** Used for the hands-free operation.
- 12 Navigator Key:** Used to adjust the volume and select desired items for each function.
- 13 Flexible Outside (CO) Line Button:** Used to make or receive an outside call. Pressing this button seizes an idle outside line automatically. (Button assignment is required.) Also used as feature buttons. (Button assignment is required.)
- 14 PAUSE:** Used to insert a pause during dialing.
- 15 MESSAGE:** Used to leave a message waiting indication or call back the party who left the message waiting indication.
- 16 Message/Ringer Lamp:** When you receive a call, the lamp flashes red. When someone has left you a message, the lamp stays on red.

◆◆ Setting

◆ Speaker/Ringer/Handset/Headset Volume

Speaker Volume	<i>While in hands-free conversation</i>	 Press UP or DOWN .
Ringer Volume	<i>While on-hook or receiving a call</i>	
Handset/Headset Volume	<i>While using the handset or headset</i>	

◆ LCD Contrast/Headset Mode

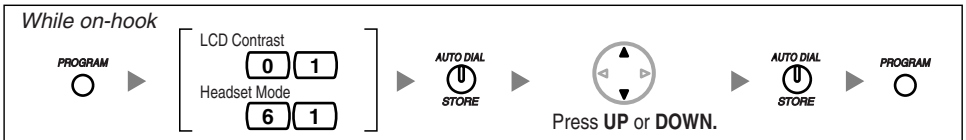

◆ Ring Tone

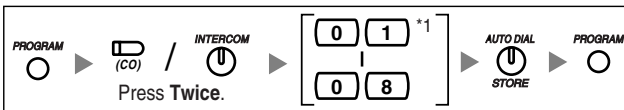

*1 The ring tone pattern of patterns 09 to 30 is the same as pattern 01.

◆ LCD Backlight

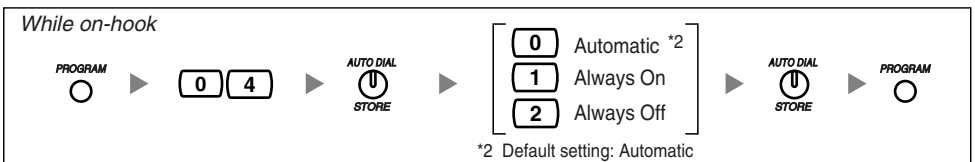

Settings on the Programming Mode

To enter the program mode		To exit	
PROGRAM ○		PROGRAM ○	
Operation			
Loop-CO (L-CO)	► ► STORE	FWD/DND - Both calls	► ► STORE
Single-CO (S-CO)	► ► STORE	FWD/DND - Outside calls	► ► STORE
Direct Station Selection	► ► STORE	FWD/DND - Intercom calls	► ► STORE
One-touch Dialing	► ► STORE	Account	► ► STORE
Incoming Call Distribution Group (ICD Group)	► ► ► STORE	Conference	► ► STORE
		Log in/ Log-out	► ► STORE
Preferred Line Assignment-Outgoing	► STORE ►	No line An idle outside line + / A CO/ICD Group button / Intercom	STORE
Preferred Line Assignment-Incoming	► STORE ►	No line The longest ringing line + / An assigned outside button	STORE
Alternate Receiving-Ring/Voice	► STORE ►	Ringing (Tone Call) Directly (Voice Call) Ring only	STORE
Call Waiting for Outside calls	► STORE ►	No (No tone) / Yes (Tone)	STORE
Call Waiting Selection	► STORE ►	No Call / Tone / Whisper OHCA	STORE
Call Waiting Tone Type Selection	► STORE ►	Tone 1 / Tone 2	STORE
Extension PIN [Personal Identification Number] (PIN-max.10 digits)	► STORE ►	To set an extension PIN [extension PIN ► STORE ► same PIN]	STORE
		To change a stored extension PIN to new one [stored extension PIN ► new PIN ► STORE ► same PIN]	
Station Programming Data Default Set	► STORE ► STORE		

Note

For your future reference

SERIAL NO. _____ DATE OF PURCHASE _____
(found on the bottom of the unit)

NAME OF DEALER _____

DEALER'S ADDRESS _____

DEALER'S TEL. NO. _____

**Panasonic Consumer Electronics Company,
Division of Panasonic Corporation of North America**

One Panasonic Way, Secaucus, New Jersey 07094

Panasonic Puerto Rico, Inc.

Ave. 65 de Infantería, Km. 9.5, San Gabriel Industrial Park,
Carolina, Puerto Rico 00985

<http://www.panasonic.com/csd>

© 2006 Panasonic Communications Co., Ltd. All Rights Reserved.

PSQX4007ZA KK0306SY0